

# Owner's Information Manual

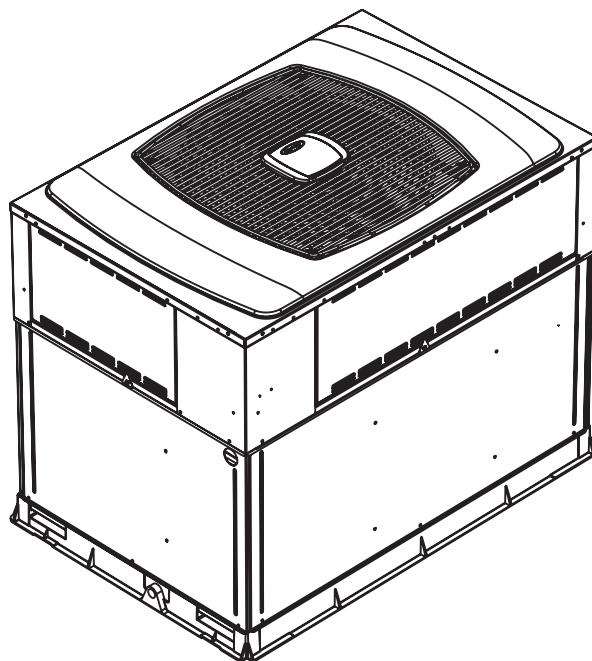

Fig. 1 - Unit 50XL

### NOTE TO EQUIPMENT OWNER:

For your convenience, please record the model and serial numbers of your new equipment in the spaces provided. This information, along with the installation data and dealer contact information, will be helpful should your system require maintenance or service.

#### UNIT INFORMATION

Model # \_\_\_\_\_

Serial # \_\_\_\_\_

#### ACCESSORIES (List type and model #)

\_\_\_\_\_  
\_\_\_\_\_  
\_\_\_\_\_

#### INSTALLATION INFORMATION

Date Installed \_\_\_\_\_

#### DEALERSHIP CONTACT INFORMATION

Company Name \_\_\_\_\_

Address \_\_\_\_\_

Phone Number \_\_\_\_\_

Technician Name \_\_\_\_\_

### NOTE TO INSTALLER:

This manual must be left with the equipment owner.

## SAFETY CONSIDERATIONS

Installation and servicing of this equipment can be hazardous due to mechanical and electrical components. Only trained and qualified personnel should install, repair, or service this equipment.

Untrained personnel can perform basic maintenance functions such as cleaning and replacing air filters. All other operations must be performed by trained service personnel. When working on this equipment, observe precautions in the literature, on tags, and on labels attached to or shipped with the unit and other safety precautions that may apply.

Follow all safety codes. Installation must be in compliance with local and national building codes. Wear safety glasses, protective clothing, and work gloves. Have fire extinguisher available. Read these instructions thoroughly and follow all warnings or cautions included in literature and attached to the unit.

Recognize safety information. This is the safety-alert symbol . When you see this symbol on the unit and in instructions or manuals, be alert to the potential for personal injury.

Understand these signal words: DANGER, WARNING, and CAUTION. These words are used with the safety-alert symbol. DANGER identifies the most serious hazards which **will** result in severe personal injury or death. WARNING signifies hazards which **could** result in personal injury or death. CAUTION is used to identify unsafe practices which **may** result in minor personal injury or product and property damage. NOTE is used to highlight suggestions which **will** result in enhanced installation, reliability, or operation.

**Note:** Installer: This manual should be left with the equipment user.



### CAUTION

#### FOR YOUR SAFETY

Failure to follow this caution may result in personal injury.

Do not store or use gasoline or other flammable vapors and liquids in the vicinity of this or any other appliance.



### WARNING

#### FIRE, EXPLOSION, ELECTRICAL SHOCK HAZARD

Failure to follow this warning could result in personal injury, death or property damage.

Do not use this unit if any part has been underwater. Immediately call a qualified service technician to inspect the unit and to replace any part of the control system which has been underwater.



### WARNING

#### ELECTRICAL SHOCK HAZARD

Failure to follow this warning could result in personal injury or death.

Before performing recommended maintenance, be sure the main power switch to unit is turned off.

## OPERATING YOUR UNIT

The operation of your packaged cooling system is controlled by the Infinity™ User Interface (UI). You may adjust the temperature manually through the UI or program the UI for automatic control. See UI manual for detailed instructions.

### To start the unit:

1. Turn on the electrical power supply to unit.
2. Set MODE control to desired mode and the UI for automatic control. See your UI instructions for more details.

### To shut off unit:

**Note:** If the unit is being shut down because of a malfunction, call your dealer as soon as possible.

1. Set system MODE control to OFF.
2. Turn off the electrical power supply to unit.

### Cooling Mode

With the UI control set to COOL, your unit will run in cooling mode until the indoor temperature is lowered to the level you have selected. On extremely hot days, your unit will run for longer periods at a time and have shorter “off” periods than on moderate days.

### Heating Mode (if installed with optional electric heat)

Your system may also be equipped with an electric heating source. On cold days and nights, place your UI control to HEAT and your system will automatically turn on the electric heat in order to maintain the level of comfort you have selected.

### Emergency Heating Mode

In the event of UI failure, the emergency heat mode allows your electric heating source to keep your home or office warm until your UI can be serviced. Contact your dealer for more information.

### Emergency Cooling Mode

In the event of UI failure, the emergency cooling mode allows your unit to keep your home or office cool until your UI can be serviced. Contact your dealer for more information.

## MAINTENANCE AND SERVICE

This section discusses maintenance that should be performed by your dealer and care you, as the owner, may wish to handle for your new unit.

### Routine Maintenance

All routine maintenance should be handled by skilled, experienced personnel. Your dealer can help you establish a standard procedure.



### CAUTION

#### FOR YOUR SAFETY

Failure to follow this caution may result in personal injury.

Do not store or use gasoline or other flammable vapors and liquids in the vicinity of this or any other appliance.

To assure proper functioning of the unit, flow of condenser air must not be obstructed from reaching the unit. Clearance from the top of the unit is 48 in. Clearance of at least 36 in. is required on sides except the power entry side (42 in. clearance) and the duct side (12 in. minimum clearance).

### Maintenance and Care for the Equipment Owner

Before proceeding with those things you might want to maintain yourself, please carefully consider the following:



## WARNING

### FIRE, EXPLOSION, ELECTRICAL SHOCK HAZARD

Failure to follow this warning could result in personal injury, death or property damage.

1. TURN OFF ELECTRICAL POWER TO YOUR UNIT BEFORE SERVICING OR PERFORMING MAINTENANCE.
2. When removing access panels or performing maintenance functions inside your unit, be aware of sharp sheet metal parts and screws. Although special care is taken to reduce sharp edges to a minimum, be extremely careful when handling parts or reaching into the unit.

### Air Filters

The air filter(s) should be checked at least every 3 months and changed or cleaned whenever it becomes dirty. Dirty filters produce excessive stress on the blower motor and can cause the motor to overheat and shut down.

This unit must have an air filter in place before it can be operated. These filters should be located in at least one of two places. In many applications, the installer will provide return air filter grilles mounted on the wall or ceiling of the conditioned structure. In the instance of filter grilles, the filters can simply be removed from the grille and replaced.

The other typical application is an accessory filter rack installed inside the unit itself. The following information is given to assist in changing filters used in these internal filter racks.

Table 1 indicates the correct filter size for your unit.

**Table 1—Air Filters Located Inside Unit  
(For Replacement Purposes)**

Unit Size	Quantity	Filter Size
024–030	2	12x20x1
036–060	3	12x24x1

To replace or inspect filters in accessory filter rack:

1. Remove the filter access panel (See Fig. 2) using a 5/16-in. nut driver.
2. Remove the filter(s) by pulling it out of the unit. If the filter(s) is dirty, clean or replace with a new one.

When installing the new filter(s), note the direction of the airflow arrows on the filter frame.

If you have difficulty locating your air filter(s) or have questions concerning proper filter maintenance, contact your dealer for instructions. When replacing filters, always use the same size and type of filter that was supplied originally by the installer.



## WARNING

### FIRE AND UNIT OPERATION HAZARD

Failure to follow this warning could result in personal injury, death or property damage.

Never operate your unit without filters in place. An accumulation of dust and lint on internal parts of your unit can cause loss of efficiency.

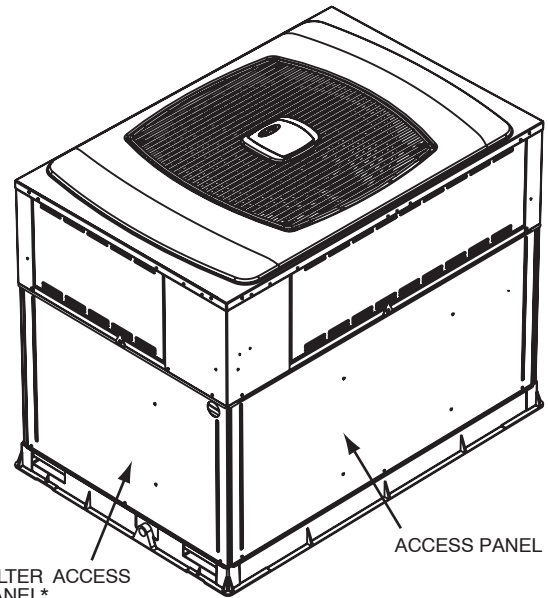

\*For accessory filter rack

**Fig. 2 - Accessory Filter Rack Access Panel**

### Fans and Fan Motor

Periodically check the condition of fan wheels and housings and fan-motor shaft bearings. Contact your dealer for the required annual maintenance.

### Indoor and Outdoor Coils

Cleaning of the coils should only be done by qualified service personnel. Contact your dealer for the required annual maintenance.

### Condensate Drain

The drain pan and condensate drain line should be checked and cleaned at the same time the cooling coils are checked by your dealer.

### Compressor

All compressors are factory shipped with a normal charge of the correct type of refrigeration grade oil. A compressor should rarely require additional oil.

### Condenser Fan



## WARNING

### PERSONAL INJURY AND UNIT DAMAGE HAZARD

Failure to follow this warning could result in personal injury, death or property damage.

Do not poke sticks, screwdrivers, or any other object into revolving fan blades.

The fan must be kept free of all obstructions to ensure proper cooling. Contact your dealer for any required service.

### Electrical Controls and Wiring

Electrical controls are difficult to check without proper instrumentation. If there are any discrepancies in the operating cycle, contact your local dealer and request service.

### Refrigerant Circuit

The refrigerant circuit is difficult to check for leaks without the proper equipment. If inadequate cooling is suspected, contact your local dealer for service.



## WARNING

### EXPLOSION AND BURN HAZARD

Failure to follow this warning could result in personal injury, death or property damage.

System under pressure. Relieve pressure and recover all refrigerant before system repair or final unit disposal. Use all service ports and open all flow-control devices, including solenoid valves.

#### Unit Panels

After performing any maintenance or service on the unit, be sure all panels are fastened securely in place to prevent rain from entering unit cabinet and to prevent disruption of the correct unit airflow pattern.

#### **Regular Dealer Maintenance**

In addition to the type of routine maintenance you might be willing to perform, your unit should be inspected regularly by a properly trained service technician. An inspection (preferably each year, but at least every other year) should include the following:

1. Inspection and, if required, cleaning of the outdoor and indoor coils.
2. Inspection and, if required, cleaning of the indoor coil drain pan.
3. Inspection and cleaning of blower wheel housing and motor.
4. Inspection of all supply and return air ducts for leaks, obstructions, and insulation integrity. Any problems found should be resolved at this time.
5. Inspection of the unit base to ensure that no cracks, gaps, etc., exist which may cause a hazardous condition.
6. Inspection of the unit casing for signs of deterioration.
7. Inspection of all electrical wiring and components to assure proper connection.
8. Inspection for leaks in the refrigerant circuit. Pressure check to determine appropriate refrigerant charge.

9. Inspection of compressor oil level by service person to ensure proper oil level is maintained in the compressor when it is installed and running.

10. Operational check of the unit to determine working conditions. Repair or adjustment should be made at this time.

Your servicing dealer may offer an economical service contract that covers seasonal inspections. Ask for further details.

Complete service instructions can be found in the unit Installation, Start-up and Service Instructions.

#### **Warranty Certificate**

Your 50XL has a limited warranty. Be sure to read the warranty carefully to determine the coverage for your unit.

#### **Before you call for service...**

...check for several easily solved problems.

#### **If insufficient heating or cooling is suspected:**

( ) Check for sufficient airflow. Check the air filter for dirt. Check for blocked return or supply air grilles. Be sure they are open and unobstructed. If these checks do not reveal the cause, call your servicing dealer.

#### **If your unit is not operating at all, check the following list for easy solutions:**

( ) Check to be sure that the temperature specified by your UI is set below the indoor temperature during the cooling season or above the indoor temperature during heating season (if equipped with electric heater). Be sure the UI is set to COOL or HEAT and not OFF.

( ) If your unit still fails to operate, call your servicing dealer for troubleshooting and repairs. Specify the model and serial numbers of your unit. (Record them in this manual in the space provided.) If the dealer knows exactly which unit you have, he may be able to offer suggestions over the phone, or save valuable time through knowledgeable preparation for the service call.

#### **In Case of Trouble**

If you perform the steps above and unit performance is still unsatisfactory, shut off the unit and call your dealer.



Turn to the Experts.™

TO OBTAIN INFORMATION ON PARTS: Consult your installing dealer or classified section of your local telephone directory under the "Heating Equipment" or "Air Conditioning Contractors & Systems" heading for dealer listing by brand name.

Have available the Model No., Series Letter, & Serial No. of your equipment to ensure correct replacement part.